

Maximize SRU Uptime 50% With Total Measurement Certainty



No Plugging

- In-Line Sulfur Condensation
- Efficient Knockout Temperature

Rapid Response

- ≤ 10 Sec Response to Excursions
- COS & CS₂ Catalyst Trending

Minimal Maintenance

- Sample & Vent Path Steam Purge
- Sealed Fiber Corrosion Protection

Flexible Installation

- Split Oven / Controller Option
- Custom Sample Port Connection

Low Cost of Ownership

- No Sample Lines or MP Steam
- No Demister / External Condenser

Brimstone Introduction

Brimstone™ is an online process analyzer designed for air demand control in sulfur recovery units (SRU). Brimstone™ controls the H₂S to SO₂ ratio to optimize elemental sulfur recovery.

Brimstone™ monitors 530 pixels from 200 to 400 nm to compensate for interferences. This fast, accurate broadband UV analysis helps operators minimize SO₂ emissions.

Brimstone™ has 40 years of field-proven experience in difficult SRU environments.

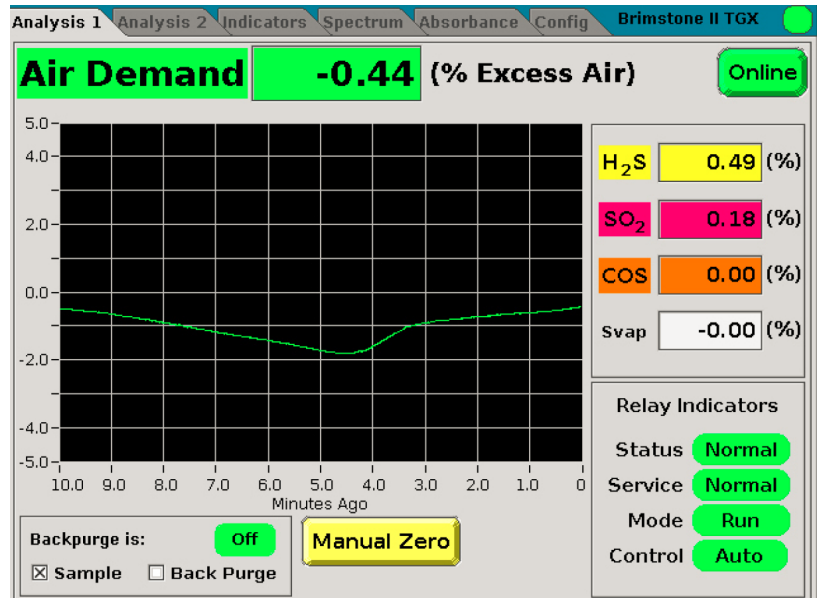

Close-Coupled Installation = No Plugging

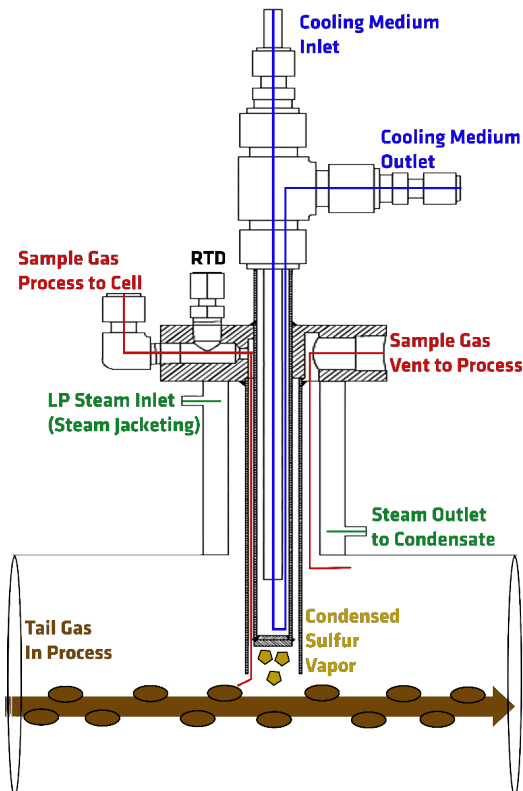

“Cold Finger” Sample Probe

Brimstone™ installs directly on to the pipe with user defined connections. The steam jacketed ball valve and sample nozzle avoid cold spots while a cooling medium condenses sulfur within the process.

The flowing tail gas enters the sample cell to be measured. The sample gas then exits the sample cell and returns to the process.

This close-coupled technique minimizes the risk of plugging. There is no external condenser, demister, or extractive process.

The robust sample system enables analysis after the first condenser. This allow for a double air demand (DAD) control strategy.

Air Purge

Vortex Cooler

**Electric
Oven
Cabinet**

**Electronics
Cabinet**

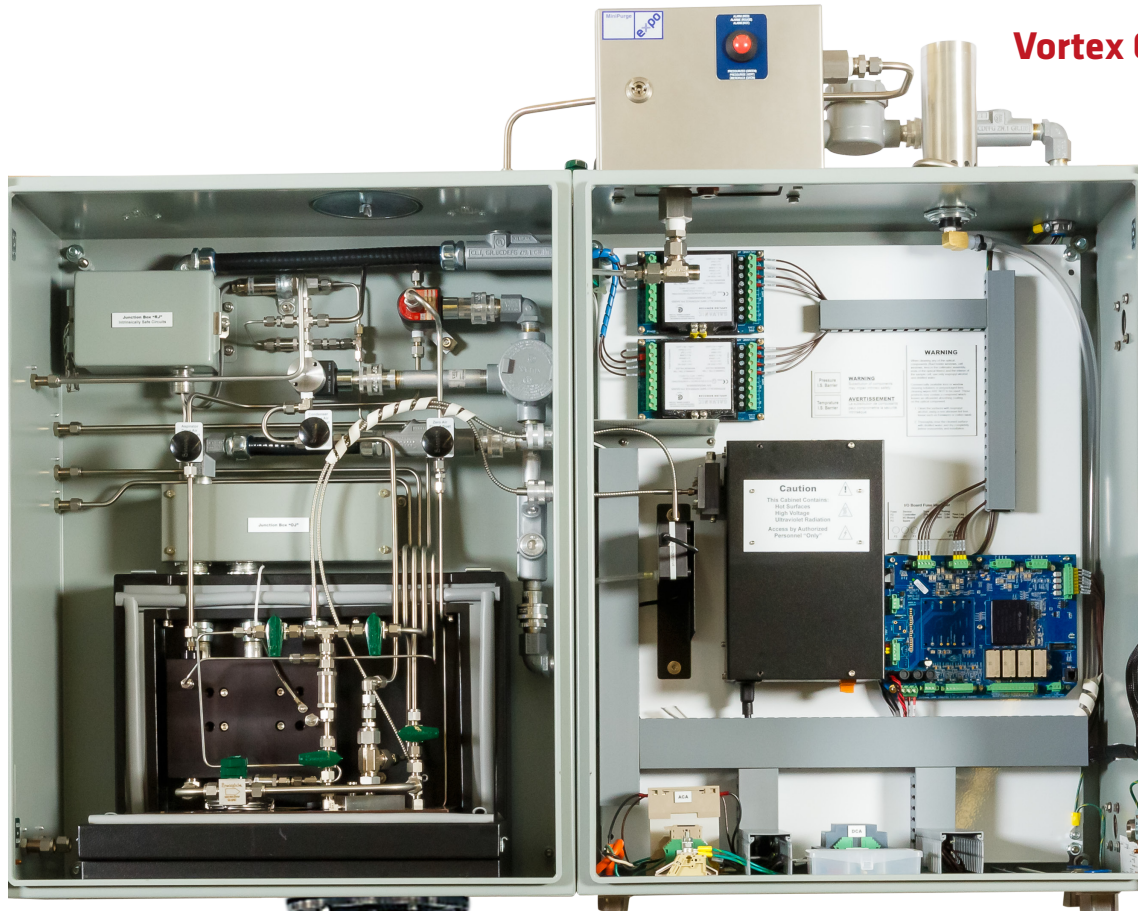

LP Steam Jacketed Nozzle **Close-Coupled
Sample Probe**

LP Steam Jacketed Ball Valve

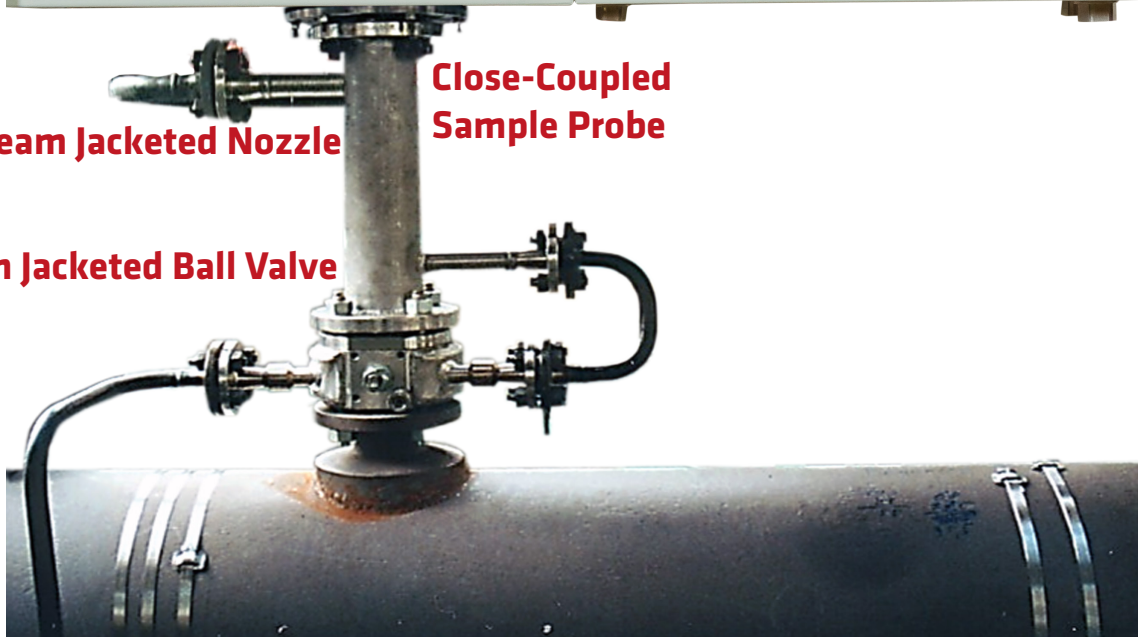

Brimstone™ 943 Tail Gas Analyzer

Engineering Drawings: 943-TGX eNA [North America]

GALVANIC
APPLIED SCIENCES

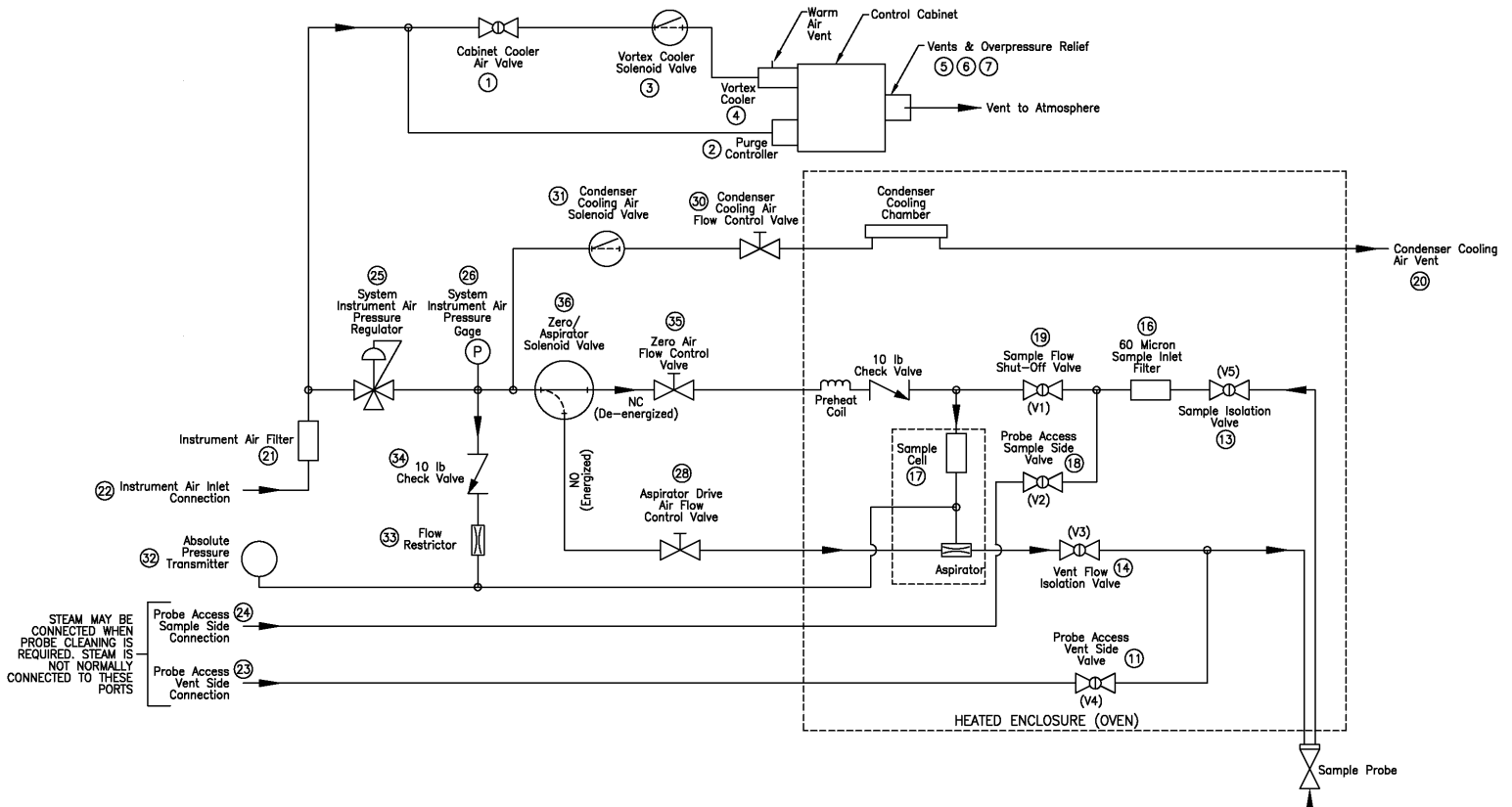
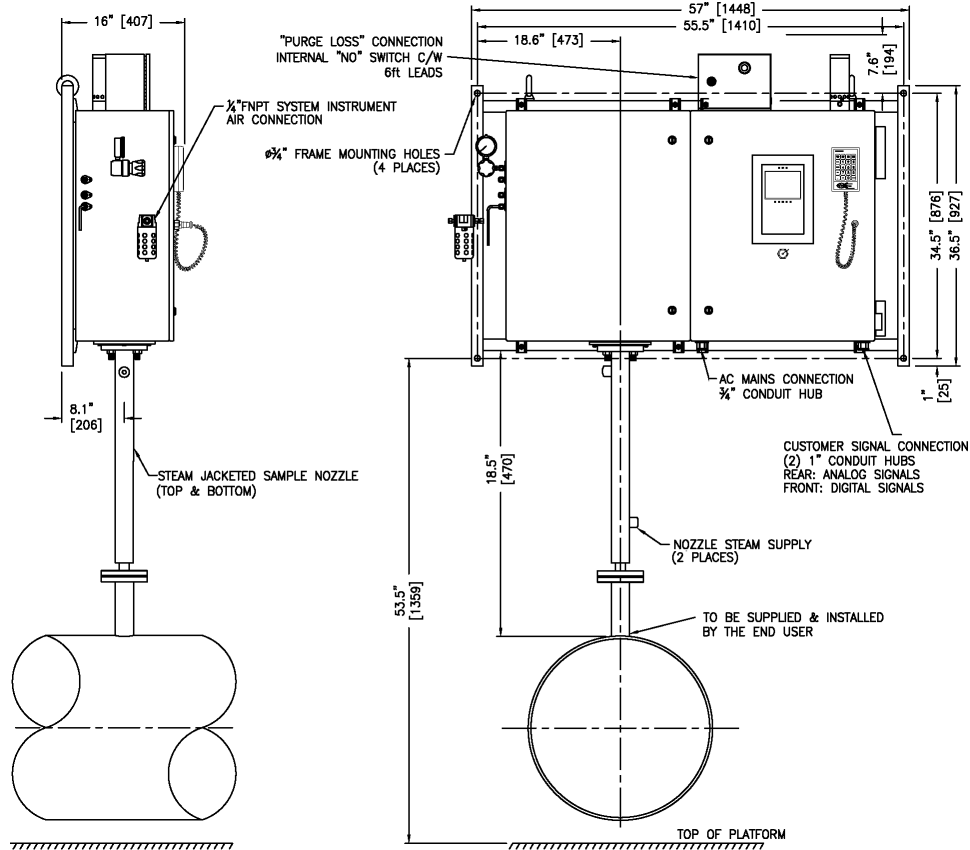

Brimstone™ 943 Tail Gas Analyzer

Engineering Drawings: 943-TGX CE [International]

GALVANIC
APPLIED SCIENCES

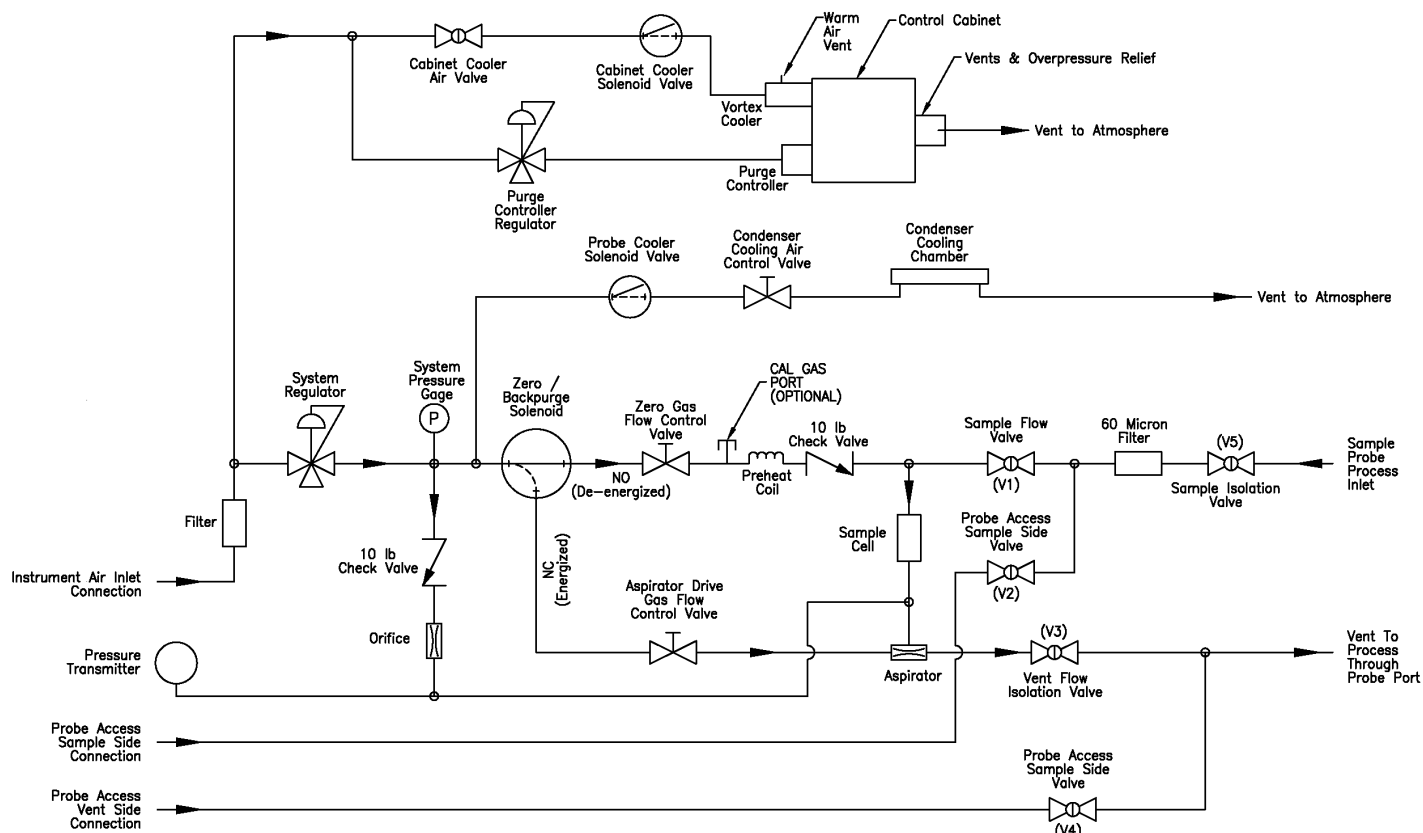
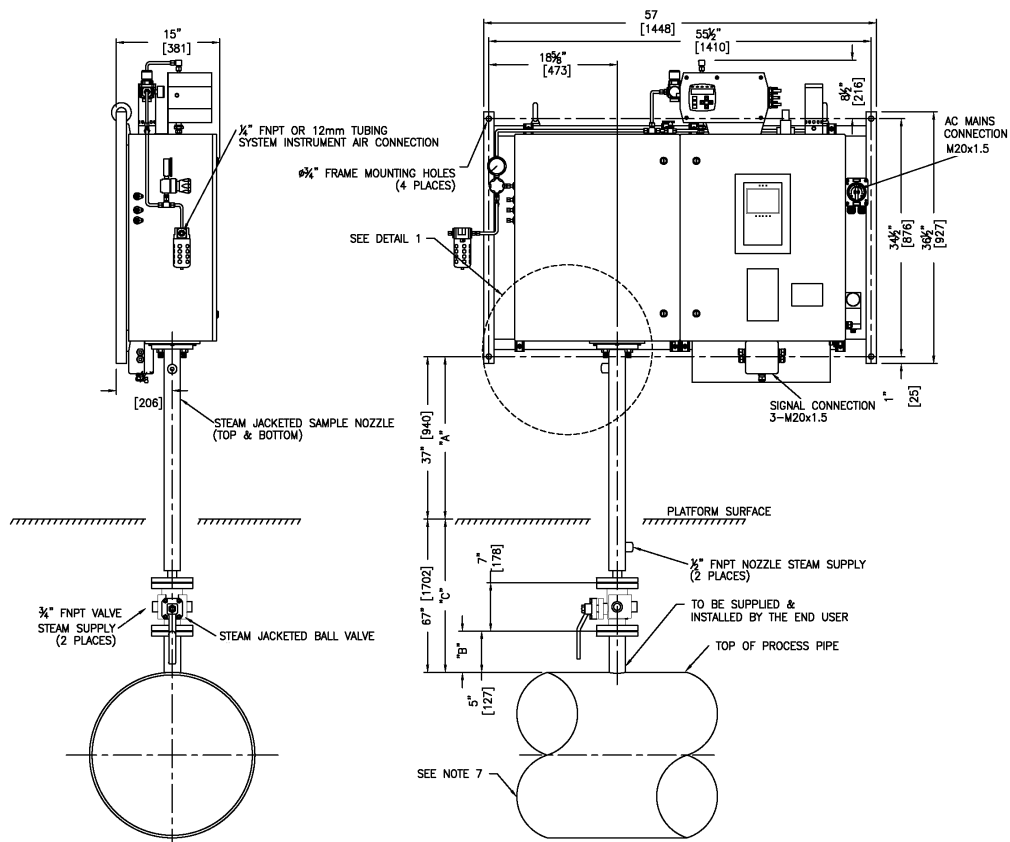

Brimstone™ 943 Tail Gas Analyzer

Engineering Drawings: 943-TGS CE [Split Oven]

GALVANIC
APPLIED SCIENCES

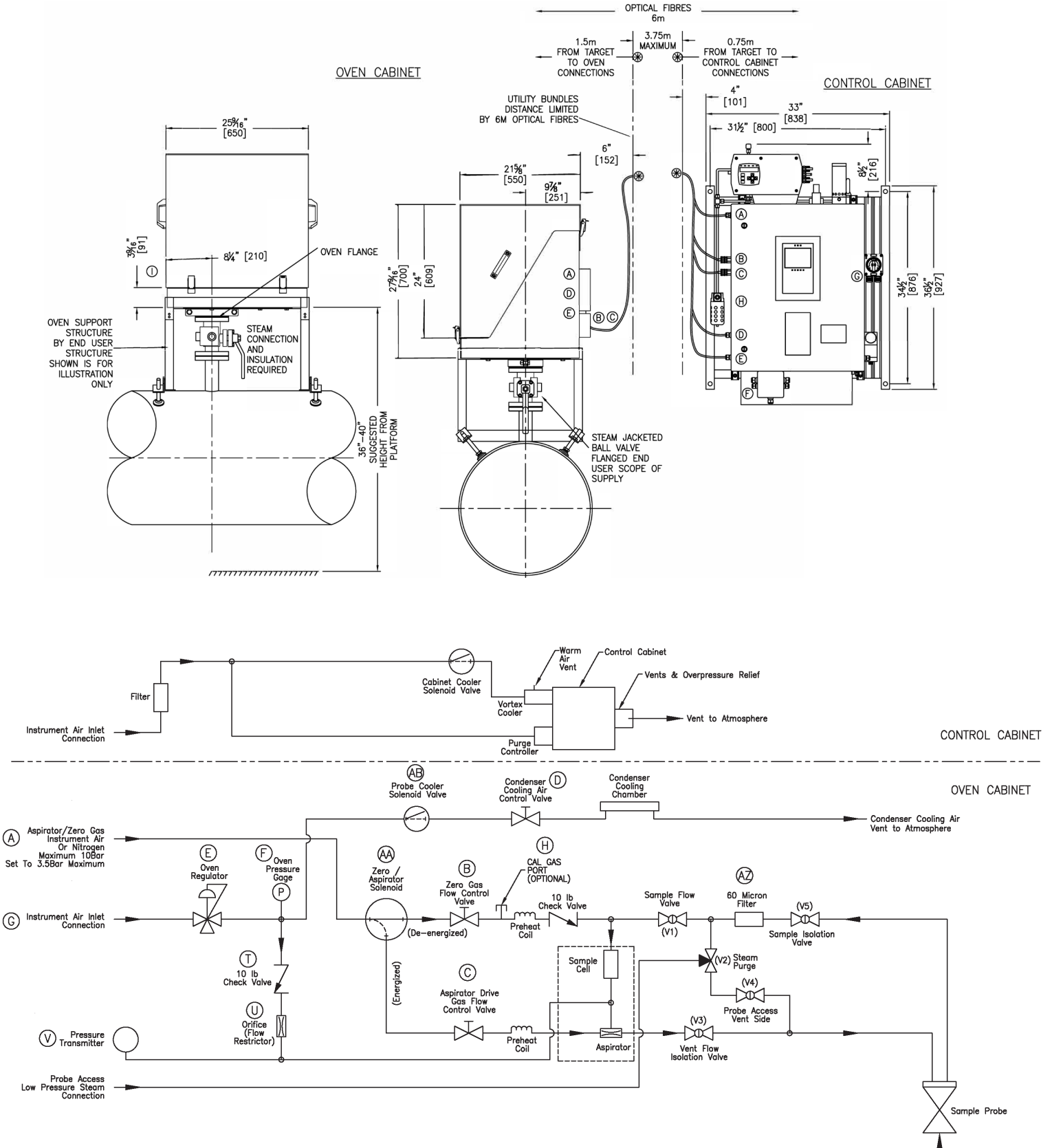

Parameter	H ₂ S	SO ₂	COS	CS ₂
Accuracy	± 1% F.S	± 1% F.S	± 5% F.S.	± 5% F.S.
Repeatability				
Linearity				
Sensitivity				
Lowest Full Scale Range	0 to 1%	0 to 0.5%	0 to 0.5%	0 to 0.5%
Highest Full Scale Range	0 to 10%	0 to 5%	0 to 2%	0 to 2%
Zero Drift	± 1% F.S. With Periodic Auto-Zero			
Response Time	T90: ≤ 10 Seconds			
Method	UV Spectrophotometry			
Measurement	200 - 400 nm Full Spectrum Analysis			
Analog Outputs	4 x 4-20mA Outputs (Loop-Powered)			
Modbus	TCP/IP or RS485I			
Digital Input	1 x Wet Contact			
Ethernet	Remote Analyzer Access Using Web-Browser Based GUI			
Analyzer Display	Color LCD With Extendable Keypad			
Power	100 - 240 VAC, 50/60 Hz			
Power Consumption	800 Watts on Start-Up / 350 Watts Operating			
Sample Flow	Adjustable Via Aspirator Drive Medium Settings			
Instrument Air	3.8 - 8 bar, 623 L/min [55 - 115 psi, 22 SCFM]			
Nitrogen (Optional)	3.8 - 8 bar, 25 L/min [50 - 55 psi, 0.9 SCFM]			
Steam	3.4 - 3.8 bar [50 - 55 psi] For Nozzle and Ball-Valve			
Model	943-TGX eNA	943-TGX CE		
Ambient Temperature	0 to 40°C [32° to 104°F]	-20 to 60°C [-4° to 140°F]		
Relative Humidity	0 to 95% Non-Condensing			
Enclosure	Painted Steel	Stainless Steel		
Split Oven Configuration	No	Optional (Model 943-TGS CE)		
Enclosure Rating	NEMA 4X, IP65	NEMA 4, IP65		
Weight	125 kg. [275 lbs.]			
Dimensions	1,110 x 1,448 x 380 mm [43.3" x 57" x 15"]			
Certification	Class I Div. 2 CD T3 (Group B Optional)	ATEX /IECEx Zone 1  Ex II 2 G 943-TGX-CE: Ex db eb ia mb pxb IIC T3 Gb 943-TGS-CE: Ex eb ia mb pxb IIC T3 Gb IP65 Analyzer Oven: Ex db eb ia mb IIC T3 Gb IP65 Ta=-20 to +60°C Russia EX EAC		
Double Air Demand	Optional Control Strategy (2 Tail Gas Analyzers With Programmed PLC)			

Digital Copies Available

